

Joe Bonham, President
Kit Jones, Vice-President
Terry Gaul, Treasurer
Nancie Rain, Secretary



Tim Jeffcoat, Director
Becky Haas, Director
William Morefield III, Director

RICHMOND

DEVELOPMENT CORPORATION OF RICHMOND

PUBLIC NOTICE OF MEETING

A meeting of the Board of Directors of the Development Corporation of Richmond **will be held at the Commission Chamber, Richmond City Hall Annex, 600 Morton Street, Richmond, Texas, on the 8th day of March 2022 commencing at 6:00 p.m. and**

via Video Conference call

(pursuant to Texas Government Code, Section 551.127)

Join Zoom Meeting

<https://us06web.zoom.us/j/81344502113>

Meeting ID: 813 4450 2113

One tap mobile

+13462487799,,81344502113# US (Houston)

+16699006833,,81344502113# US (San Jose)

Dial by your location

+1 346 248 7799 US (Houston)

+1 669 900 6833 US (San Jose)

+1 253 215 8782 US (Tacoma)

+1 312 626 6799 US (Chicago)

+1 929 205 6099 US (New York)

+1 301 715 8592 US (Washington DC) Meeting ID: 813 4450 2113 Find your local number: <https://us06web.zoom.us/j/81344502113>

A quorum of the City Commission may be present at this meeting.

1. Call to Order.
2. Recite the Pledge of Allegiance to the U.S. Flag and Texas Flag.
3. Public Comments. (Public comment is limited to a maximum of 3 minutes per item. No deliberations with DCR Board. Time may not be given to another speaker.)
4. Review and consider taking action on the minutes of the regular meeting held on February 8, 2022.
5. Review Financial Reports through February 28, 2022.
6. Review and Discuss Future planned TX Dot improvements on FM 359.
7. Review and Discuss Richmond's Economic Development Office and Small Business Accelerator Space Project
8. Report of activities of Economic Development Director.
9. Excuse from Attendance at Regular DCR Meeting.
10. Adjourn to Executive Session, as authorized by Texas Government Code, Section 551.087, Deliberation Regarding Economic Development Negotiations.

11. EXECUTIVE SESSION

In accordance with Chapter 551, Government Code, Vernon's Texas Code Annotated (V.T.C.A.) (Open Meetings Law), "The Board of Directors may meet in a Closed Executive Meeting pursuant to provisions of the Open Meetings Law, Chapter 551, Government Code, V.T.C.A. in accordance with the authority contained in the following section"; Section 551.087, Deliberation Regarding Economic Development Negotiations.

- E1. Hanger
- E2. Smokey
- E3. Circle Oak Updates

OPEN MEETING

DEVELOPMENT CORPORATION OF RICHMOND

12. Reconvene into Open Meeting, and take action on items, if necessary.
13. Adjournment

NOTICE OF ASSISTANCE AT THE PUBLIC MEETING

The Development Corporation of Richmond (DCR) meetings are available to all persons regardless of disability. This facility is wheelchair accessible and accessible parking spaces are available. Requests for accommodations, should you require special assistance, must be made 48 hours prior to this meeting. Braille is not available. Please contact the City Secretary's office at (281) 342-5456 for needed accommodations.

CERTIFICATE

I certify that the above notice of meeting was posted on a bulletin board located at a place convenient to the public in the City Hall, Richmond, Texas, on the 4th day of February 2022, at ____ a.m./p.m.

Laura Scarlato City Secretary

1. Call to Order.



RICHMOND
DEVELOPMENT CORPORATION OF RICHMOND

2. Recite the Pledge of Allegiance to the U.S. Flag and Texas Flag.



RICHMOND
DEVELOPMENT CORPORATION OF RICHMOND

The United States Pledge of Allegiance:

I pledge allegiance to the Flag of the
United States of America, and to the
Republic for which it
stands, one Nation
under God, indivisible,
with liberty and
justice for all.



The Texas Pledge of Allegiance:

Honor the Texas flag;

I pledge allegiance to

thee, Texas, one state

under God, one and

indivisible.



3. Public Comments.
(Public comment is limited to a maximum of 3 minutes per item. No deliberations with DCR Board. Time may not be given to another speaker.)

4. Review and consider taking action on the minutes of the regular meeting held on February 8, 2022.

**5. Review Financial
Reports through
February 28, 2022.**

RICHMOND
DEVELOPMENT CORPORATION OF RICHMOND

**6. Review and Discuss
Future planned TX Dot
improvements on FM
359.**





PLANT SCHEDULE FM359 0543-02-079

TREE	CODE	BOTANICAL / COMMON NAME
	QV	QUERCUS VIRGINIANA SOUTHERN WHITE OAK
	QS	QUERCUS SHUMARDII SHUMARD OAK
	AT	ASTRAGALUS TRIFLORUS CAPE MYRTLE

NOTE
 SITE LOCATION SHEETS ARE DIAGHRAGMATIC REPRESENTATIONS OF PROPOSED WORK AREAS ONLY. CONTRACTOR IS RESPONSIBLE FOR LOCATING AND STAKING LIMITS OF EACH BED PREPARATION AREA IN ACCORDANCE WITH PLANS. ADJUSTMENTS WILL BE MADE TO ACCOMMODATE SITE CONDITIONS. ALL LOCATIONS WILL BE APPROVED PRIOR TO ANY BED PREPARATION WORK.

INTERIM REVIEW
 THESE DOCUMENTS ARE INTENDED FOR INTERIM REVIEW ONLY AND NOT FOR REGULATORY APPROVAL, PERMITTING, OR CONSTRUCTION.
 REGISTERED LANDSCAPE ARCHITECT
 PATRICK OWENS
 TEXAS REGISTRATION NUMBER 1958



Pacheco Koch 30329 STATE HIGHWAY 344, STE. 200 HOUSTON, TX 77078 281-862-8800 TX REG. OVERSEER FILE # 1-000 TX REG. SURVEYOR FILE LB-0163300

Texas Department of Transportation

FM359 SITE LOCATION

CSJ: 0543-02-079 SHEET 1 OF 1

NO. 05	FEDERAL AID PROJECT NO.	SHEET NO.
05		035
STATE	DISTRICT	COUNTY
TEXAS	HOU	FORT BEND
CONTRACT	SECTION	JOB
0027	12	186, ETC.
		IN 89

SHEET 1 OF 1
 DATE: 05/14/2018
 BY: J. OWENS
 PROJECT: FM359 0543-02-079

7. Review and Discuss Richmond's Economic Development Office and Small Business Accelerator Space Project

RICHMOND
DEVELOPMENT CORPORATION OF RICHMOND



RICHMOND
EST. **TEXAS** 1837

City of Richmond—Economic Development Dept. Buildout

January 21, 2022

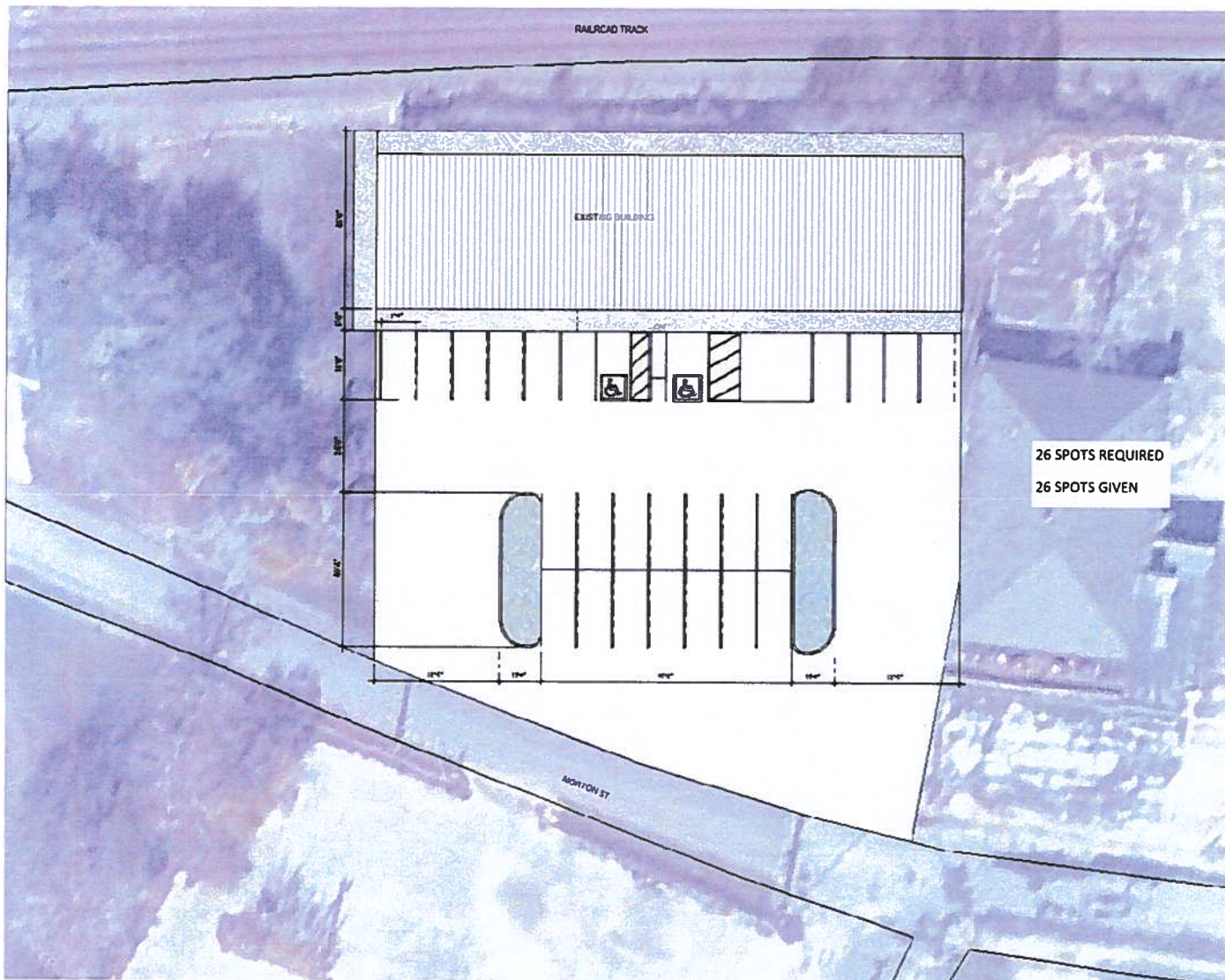

MYRTLE STREET BUILDOUT—SITE PLAN

Finish Review Board
January 21, 2022

3131 BRIARPARK DR
SUITE 200
HOUSTON, TX 77042

[T] 713 622 1444
[F] 713 968 9333

WWW.PGAL.COM



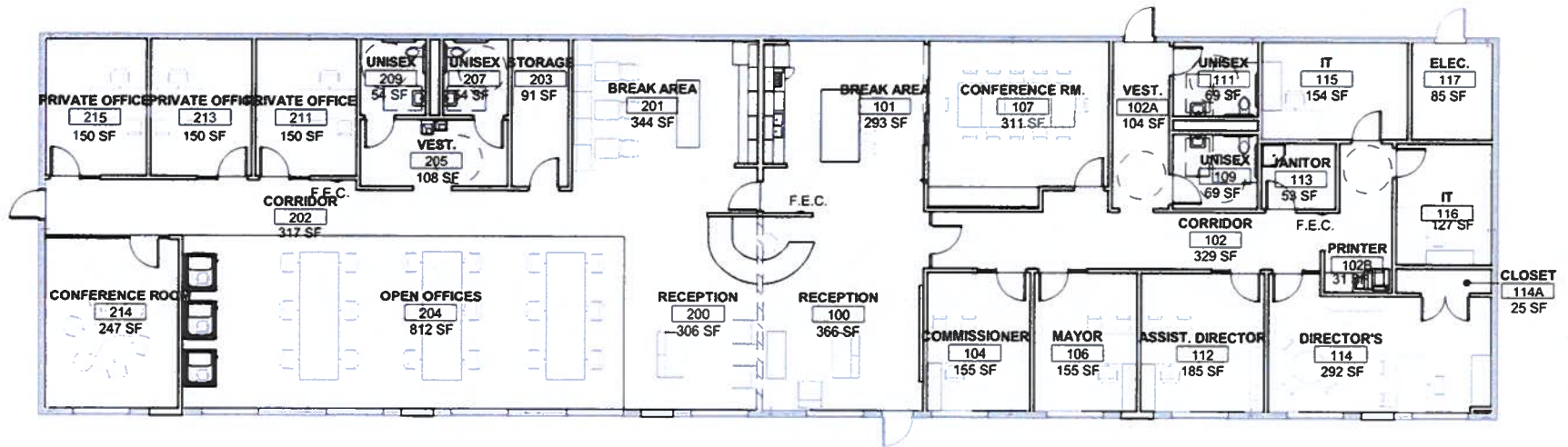

MYRTLE STREET BUILDOUT—OVERALL FLOORPLAN

Finish Review Board
January 21, 2022

333 BRIARPARK DR
SUITE 200
HOUSTON, TX 77042

[T] 713 622 1444
[F] 713 968 9333

WWW.PGAL.COM





Ceiling Inspiration

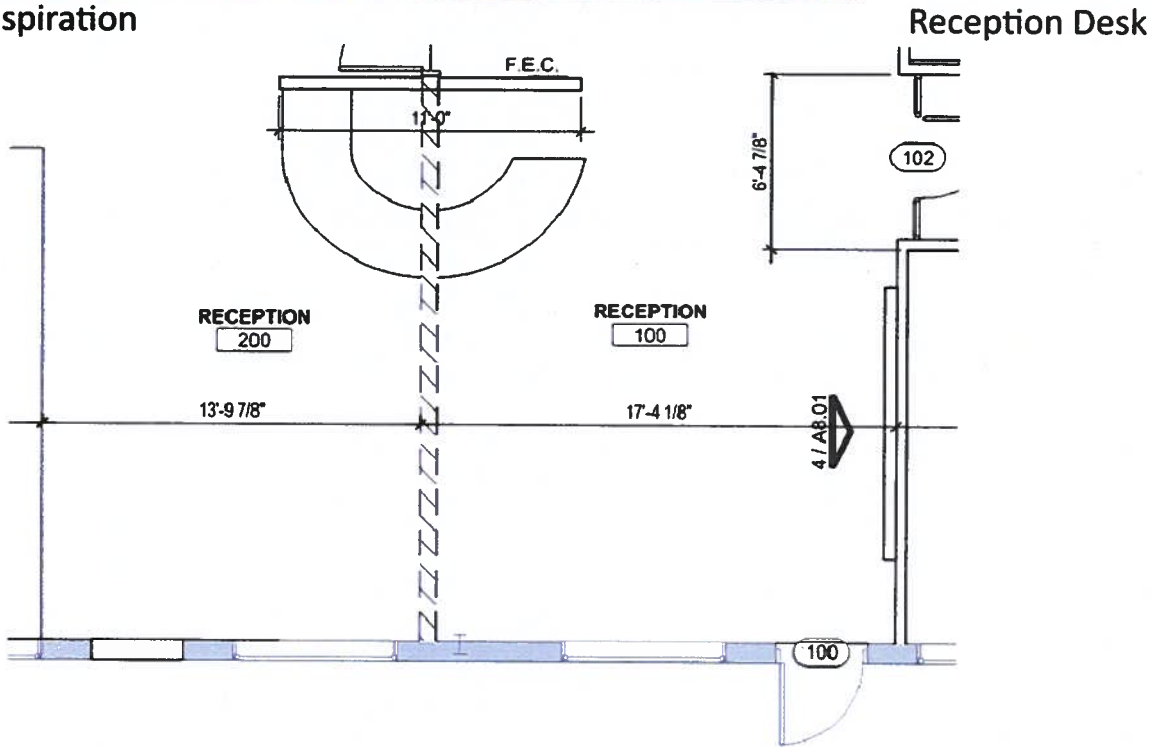

Reception Desk



Gallery Wall



Luxury Vinyl Tile



MYRTLE STREET BUILDOUT—RECEPTION

Finish Review Board
January 21, 2022

3131 BRIARPARK DR.
SUITE 200
HOUSTON, TX 77062

[T] 713 622 1444
[F] 713 968 9333

WWW.PGAL.COM



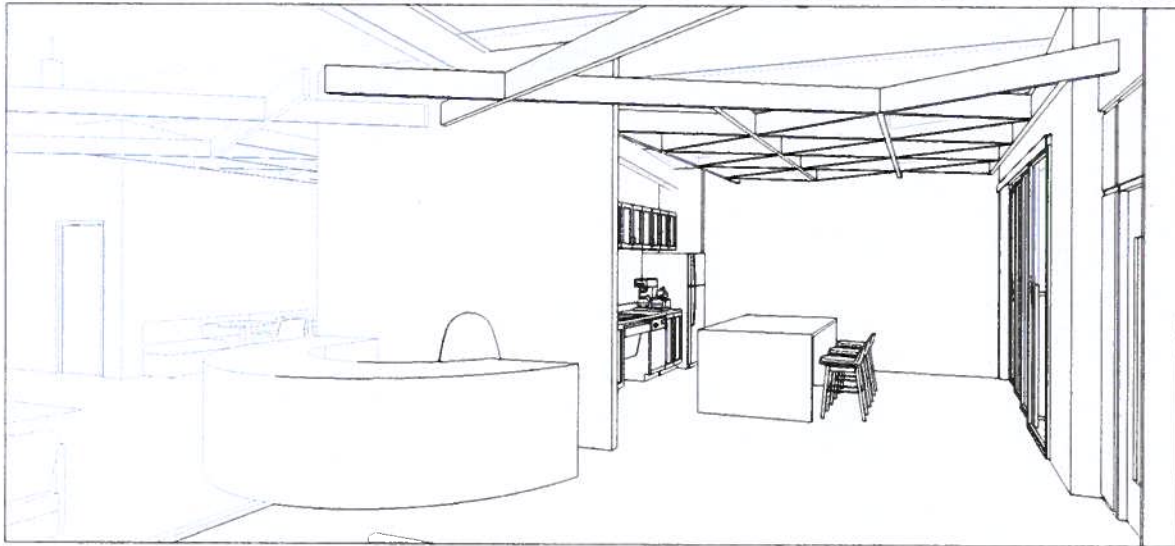
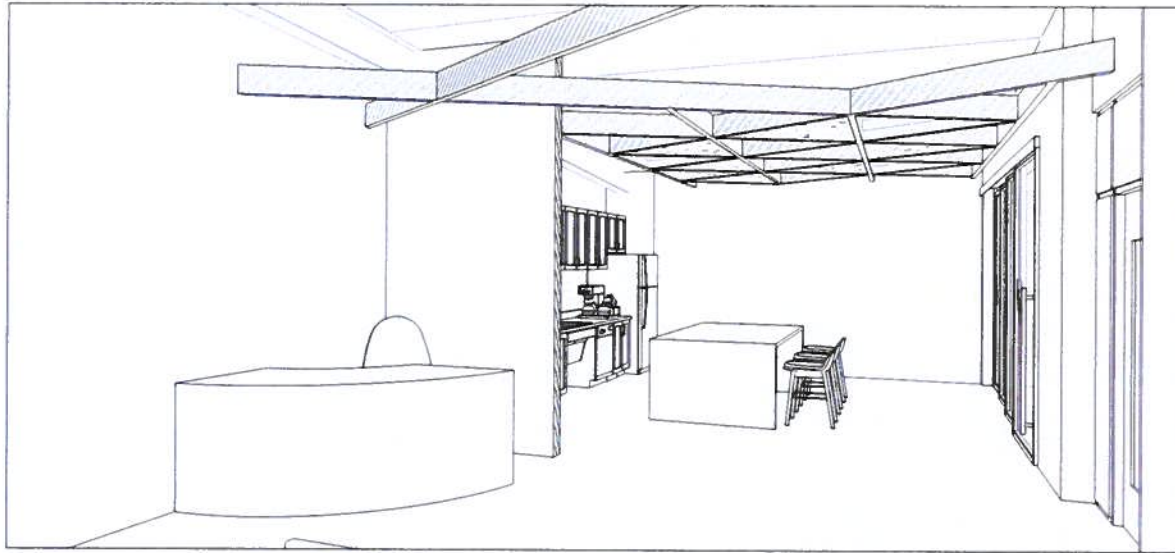

MYRTLE STREET BUILDOUT—RECEPTION PHASING

Finish Review Board
January 21, 2022

333 BRIARPARK DR
SUITE 200
HOUSTON, TX 77042

[T] 713 622 1444
[F] 713 968 9333

WWW.PGAL.COM



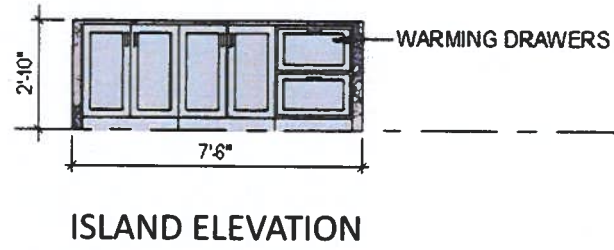
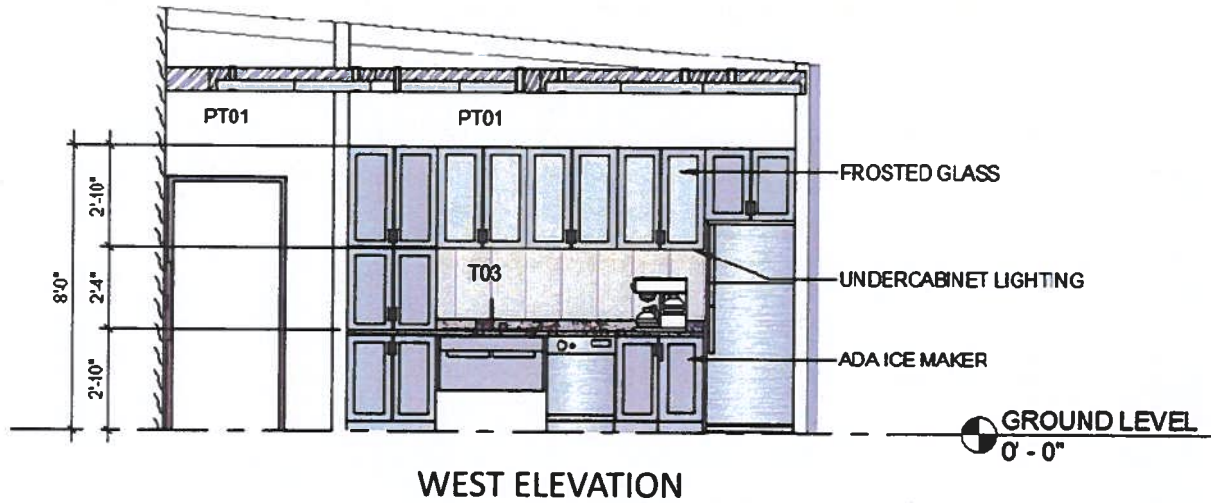
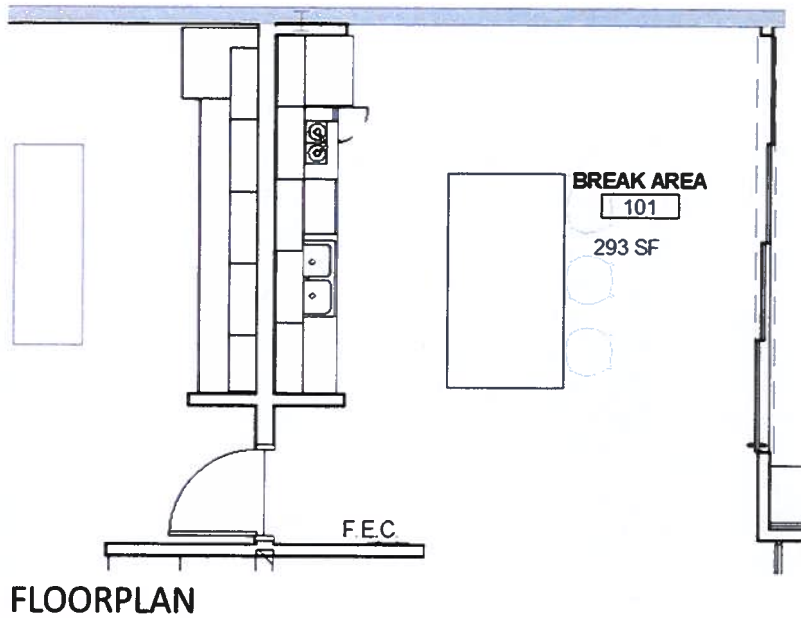

MYRTLE STREET BUILDOUT—BREAK AREA

Finish Review Board
January 21, 2022

333 BRIARPARK DR
SUITE 200
HOUSTON, TX 77042

[T] 713 622 1444
[F] 713 968 9333

WWW.PGAL.COM





BACKSPLASH

PAINTED MILLWORK

ISLAND FRONT



COUNTER STOOLS



MYRTLE STREET BUILDOUT—BREAK AREA

Finish Review Board
January 21, 2022

333 BRIARPARK DR.
SUITE 200
HOUSTON, TX 77042

[T] 713 622 1444
[F] 713 968 9333

WWW.PGAL.COM



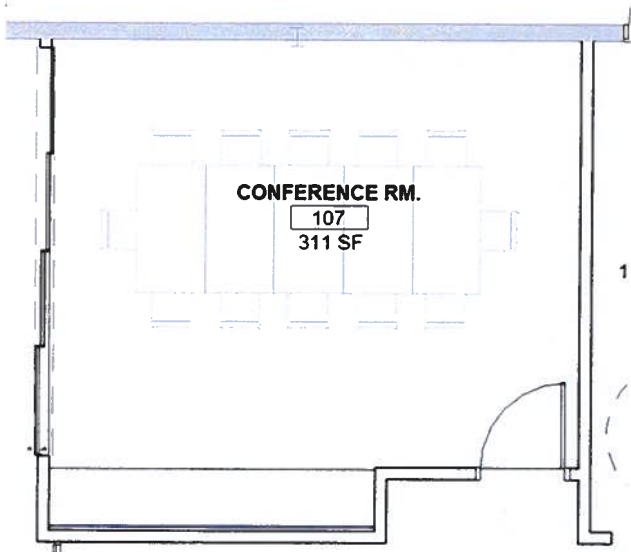

FLOORPLAN



CUSTOM PET CEILING PANEL

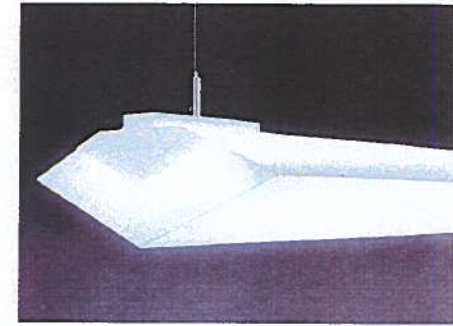

PENDANT LIGHT FIXTURE

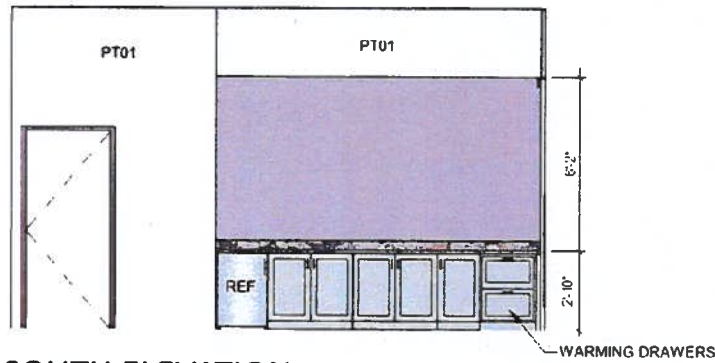

SOUTH ELEVATION

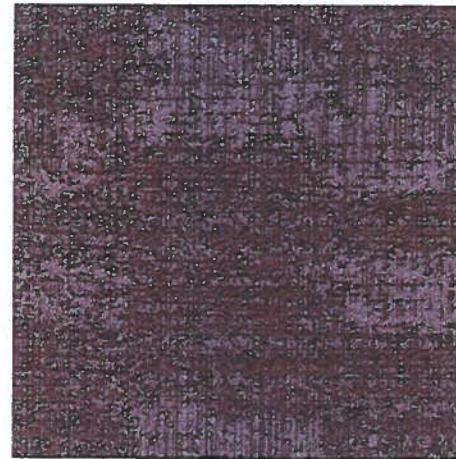

KINETEX 24\"/>

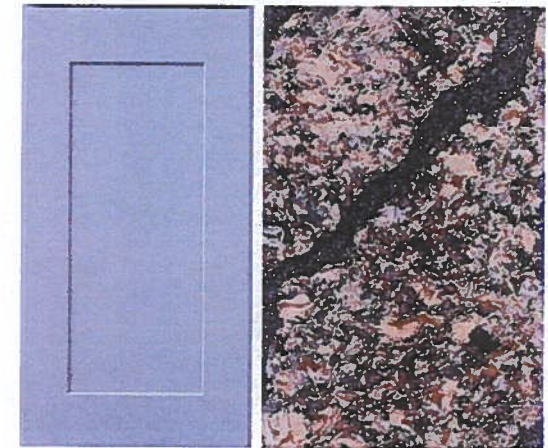

MILLWORK FINISHES



MYRTLE STREET BUILDOUT—CONFERENCE ROOM

Finish Review Board
January 21, 2022

373 BRIARPARK DR
SUITE 200
HOUSTON, TX 77042

[T] 713 622 1444
[F] 713 968 9333

WWW.PGAL.COM





Sherwin Williams SW7004 Snowbound



Sherwin Williams SW6991 Black Magic



Sherwin Williams SW7595 Sommelier



Sherwin Williams SW7669 Summit Gray



Sherwin Williams SW6214 Underseas



MYRTLE STREET BUILDOUT—GRAPHIC WALL OPTION

Finish Review Board
January 21, 2022



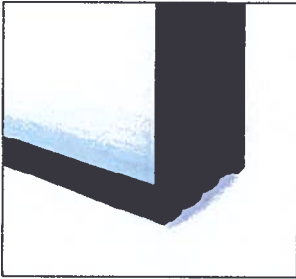
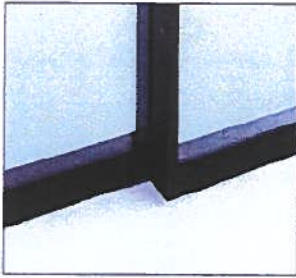

STACKING

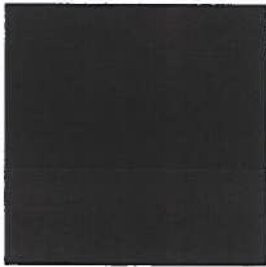

BRONZE FINISH



TELESCOPING DOOR PANEL



MYRTLE STREET BUILDOUT—TELESCOPING DOOR PANEL

Finish Review Board
January 21, 2022

333 BRIARPARK DR.
SUITE 200
HOUSTON, TX 77062

[T] 713 622 1444
[F] 713 968 9333

WWW.PGAL.COM



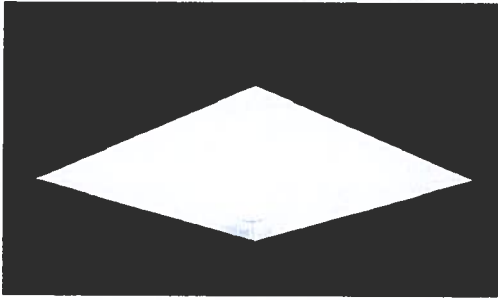

2'X2' LIGHT FIXTURE



RUBBER BASE PROFILE

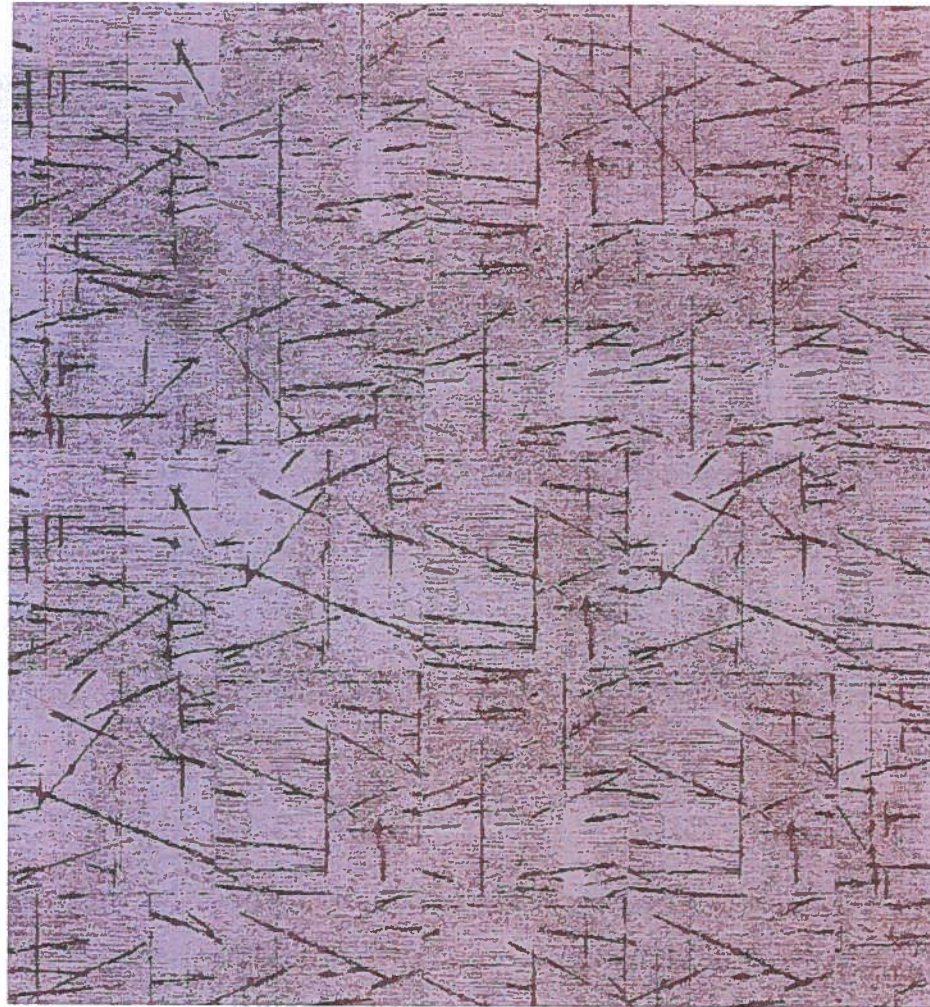

CARPET TILE

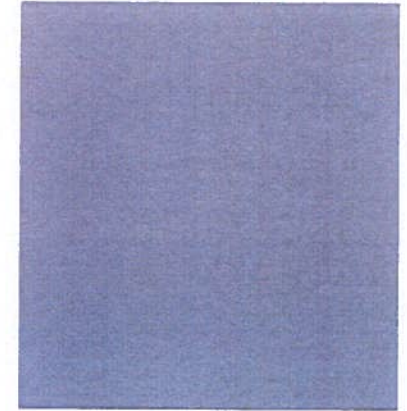

ACCENT PAINT

PAINT



MYRTLE STREET BUILDOUT—OFFICES

Finish Review Board
January 21, 2022

333 BRIARPARK DR.
SUITE 200
HOUSTON, TX 77042

[T] 713 622 1444
[F] 713 968 9333

WWW.PGAL.COM



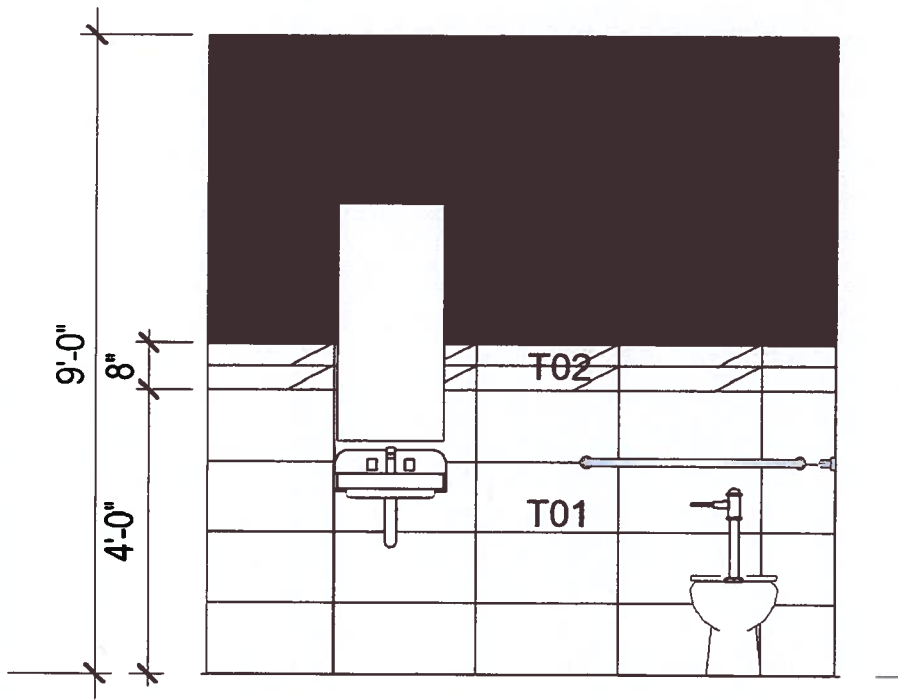

LAVATORY ELEVATION



PAINT

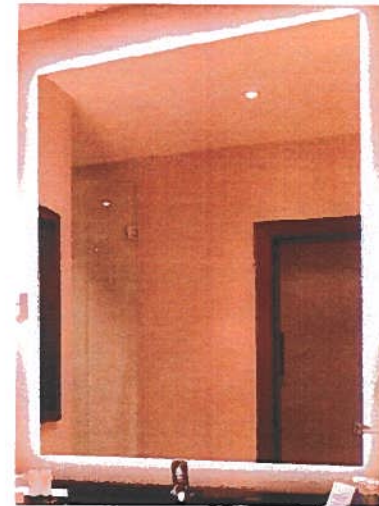

BACKLIT MIRROR

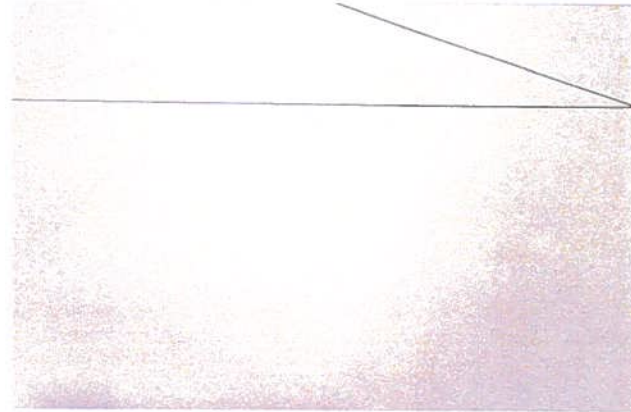

FLOOR AND WALL TILE



GROUT



MYRTLE STREET BUILDOUT—RESTROOMS

Finish Review Board
January 21, 2022

3031 BRIARPARK DR.
SUITE 200
HOUSTON, TX 77042

[T] 713 622 1444
[F] 713 968 9333

WWW.PGAL.COM



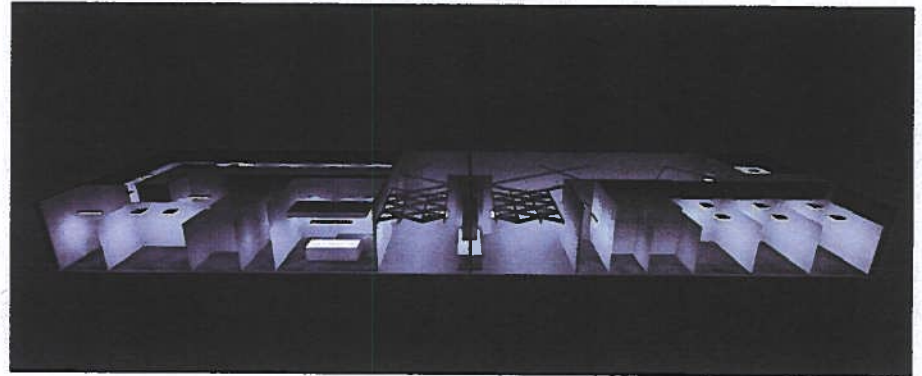
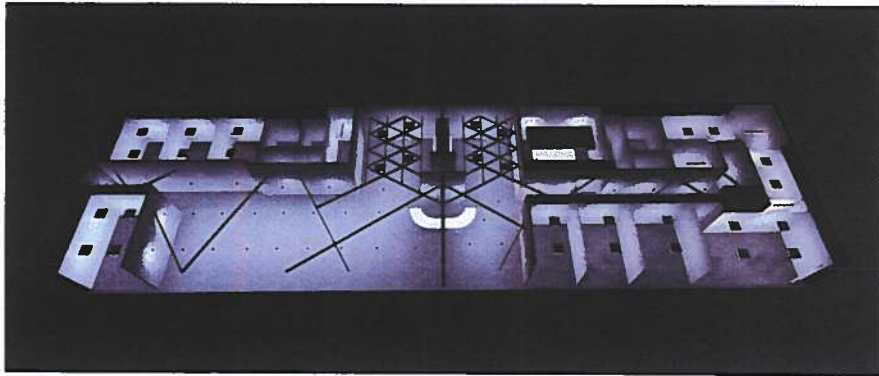
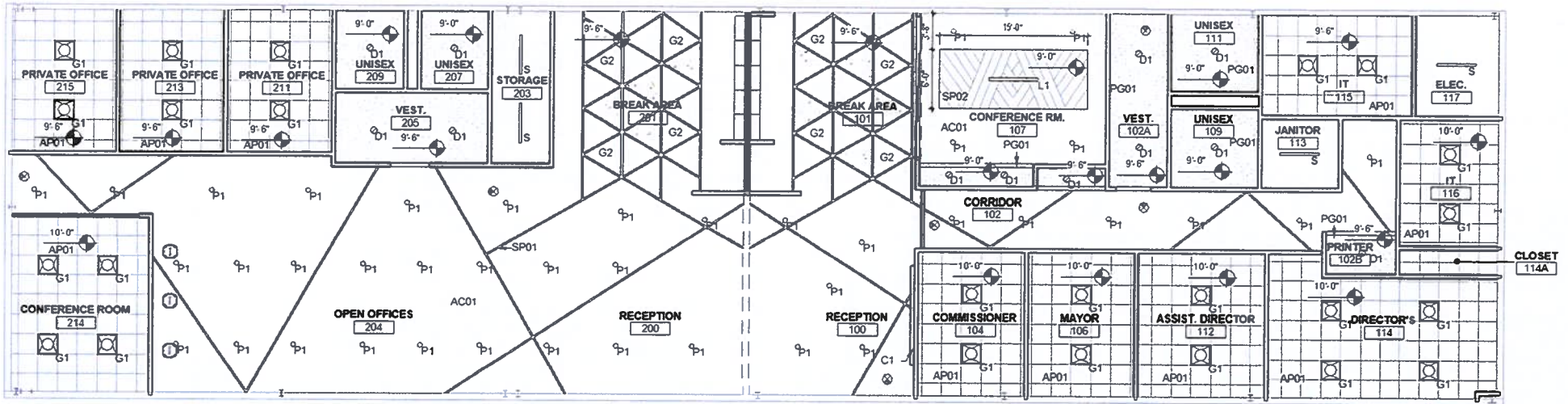

MYRTLE STREET BUILDOUT—REFLECTED CEILING PLAN

Finish Review Board
January 21, 2022

333 BRIARPARK DR.
SUITE 200
HOUSTON, TX 77022

T 713 627 1444
F 713 968 9333

WWW.PGAL.COM



8. Report of activities of Economic Development Director.



9. Consider taking
action on requests for
future agenda items.



RICHMOND
DEVELOPMENT CORPORATION OF RICHMOND

10. Excuse from Attendance at Regular DCR Meeting.



11.) EXECUTIVE SESSION

In accordance with Chapter 551, Government Code, Vernon's Texas Code Annotated (V.T.C.A.) (Open Meetings Law), "The Board of Directors may meet in a Closed Executive Meeting pursuant to provisions of the Open Meetings Law, Chapter 551, Government Code, V.T.C.A. in accordance with the authority contained in the following section"; Section 551.087, Deliberation Regarding Economic Development Negotiations.

E1. Hanger

E2. Smokey

E3. Circle Oak Update

OPEN MEETING

12. Reconvene into Open Meeting, and take action on items, if necessary.

RICHMOND
DEVELOPMENT CORPORATION OF RICHMOND

13. Adjournment

